

Series 9300 Casement Window Installation Instructions

Installation Requires Knowledge of:

- AAMA Installation Instructions.
- Applicable Federal, State, Local Codes and Regulations.
- An Understanding of the Fundamentals of Residential Construction.
- A Working Knowledge of the Tools, Equipment and Methods Required for Installation.
- A Familiarity with Caulking, Sealing Procedures and Glass Handling Procedures.

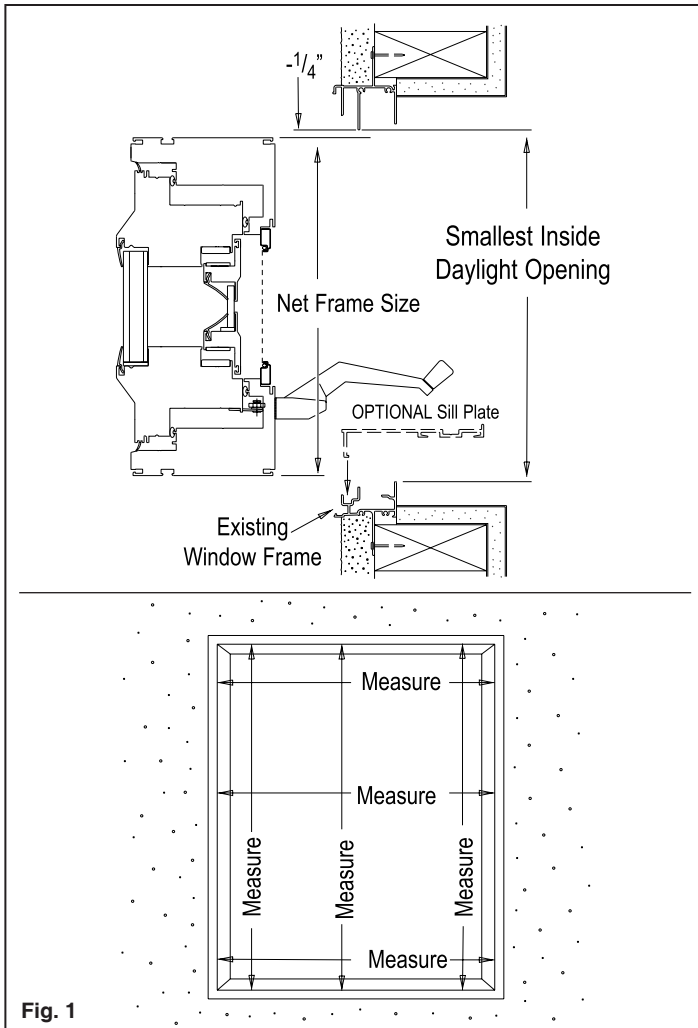

Fig. 1

The Installation covered here **REQUIRES** the following **OPTIONAL** items supplied by IWC:

- Sill Plate*
- Exterior Trims*
- Interior Trims*

1. Measuring Window Opening

A. Measure the opening in your existing window. The narrowest measurements in your window opening, excluding the fixed and sash panels, will be the "daylight opening". Measure existing daylight opening at the ends and the center. See **Fig. 1**. Deduct 1/4" from both

Tools and Materials You Will Need

A few simple hand tools will aid in installation. Refer to the specific installation method instructions for materials required.

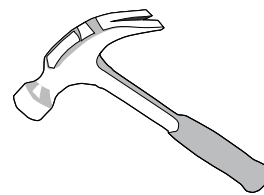

Hammer

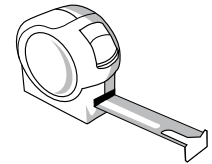

Tape Measure



Broad Wood Chisel

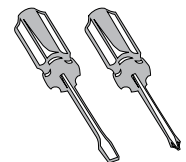

**Flat and Phillips-head
Screwdrivers**



Utility Knife

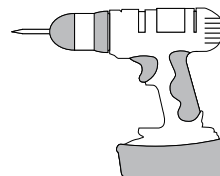

Drill

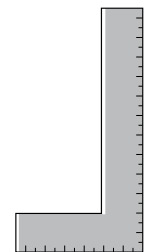

Square

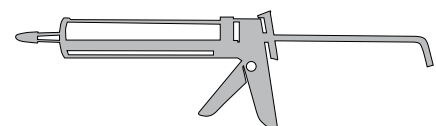

Caulking Gun



Level

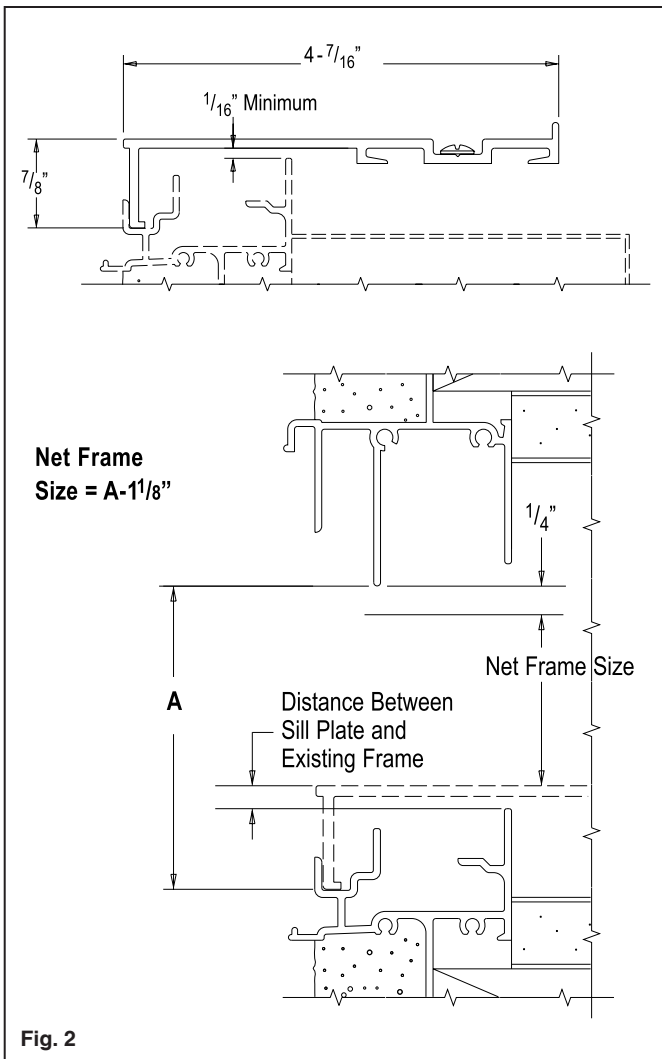

Fig. 2

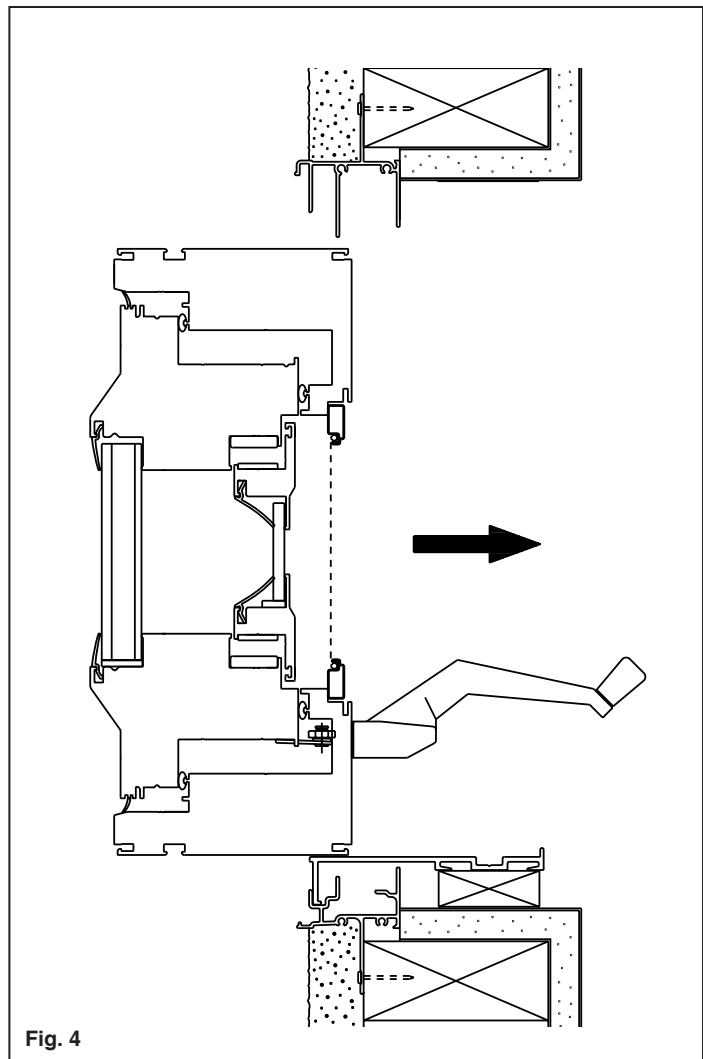

Fig. 4

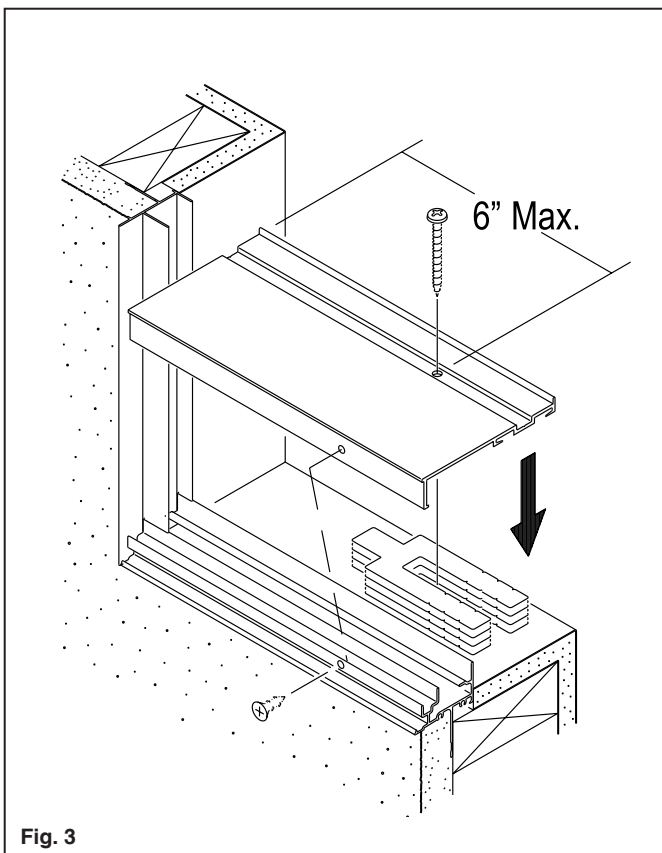

Fig. 3

the width and height of the daylight opening dimensions. A deduction for the distance between the top of the Sill Plate and the tallest wall on the existing sill is also needed to determine the "net frame size". See **Fig. 2**. Consider the best location for installing the Sill Plate in the existing sill and then take your measurements.

2. Sill Plate Installation

A. Sill Plate should be cut to fit over existing sill and touch both existing jambs.

B. Horse Shoe shims or equal, are needed to support the Sill Plate at installation screw locations. Make sure Sill Plate is straight and level prior to fastening. Screws should be no more than 18" apart on center, with corner screws approximately 6" from jambs. See **Fig. 3**. Use #8 x 2" Phillips sheet metal screws. Length of screw may vary per job condition. Screws must be long enough to secure Sill Plate to existing wood sill. Anchor the exterior leg of the Sill Plate to the existing sill with #6 x 1/4" Phillips flat head sheet metal screws. Seal screw heads with an appropriate sealant after installing.

3. Frame Installation

A. Slide the new frame into the opening. See **Fig. 4**. Center frame between existing jambs and use shims to straighten and square frame. Wood filler

blocks may be used to fill gaps between new and existing frames, but leave a small gap at the head for deflection. Measure frame diagonally across the corners to check for squareness. Adjust if needed.

B. Screw jambs into frame opening using #10 x 2 1/2" Phillips sheet metal screws and washers. Screws must be long enough to secure new frame to existing wood frame. Extra care should be taken as the vent panel has to be in the open position in order to fasten the frame to the opening. Pop off the nylon hole caps and use the predrilled holes in the jambs for installing screws. Use the center hole only at hinge locations. See **Fig. 5**. Start with the screw at the center of the hinge jamb. With the screw secured, check the level and plumb of the jamb before continuing with the other two screws. After hinge jamb is secured, check opposite jamb for plumb, adjust if needed and fasten with screws. Reinstall nylon hole caps.

4. Installing the Screen Frame

A. Casements use an interior screen. The screen frame may or may not be installed when the unit is delivered. The screen frame is held in place in the casement frame with clips that turn and engage with the frame. Easy to install and remove.

5. Exterior Trim Installation

A. An optional flat trim material is available to finish off the exterior look. The trim material will be sealed with an appropriate sealant and snapped into the gap that follows the perimeter of the frame. See **Fig. 6**. Measure the pieces to the frame and with a sharp knife or a heavy scissor, make a 45° cut for a miter fit. Care should be taken not to over cut trim. See **Fig. 7**.

B. Use a recommended sealant for the type of job and materials being used to apply a continuous bead of sealant around the outer edge of the trim you just installed. See **Fig. 8**.

6. Interior Trim Installation

A. An optional flat vinyl interior trim is available for concealing the gap between the existing frame and the newly installed window. The trim is applied to the new frame with a double face tape. See **Fig. 9**. Measure and cut trim to fit. It is your option to use this trim or you may want to use a more decorative wood trim.

7. Cleaning Interior Sash

A. This casement window comes with a secondary sash. An L-shape janitor's key should have come with the window for operating the locks on the secondary sash. With the long end of the key, turn the top lock counter-clock wise to unlock it. See **Fig. 10**. The lock is spring loaded, so a little pressure while turning is needed. Now, take the short end, the end with the two tabs, and unlock the bottom one. The key will remain in the lock and can be used as a handle for pulling the sashes apart. To close up the unit, just reverse the process.

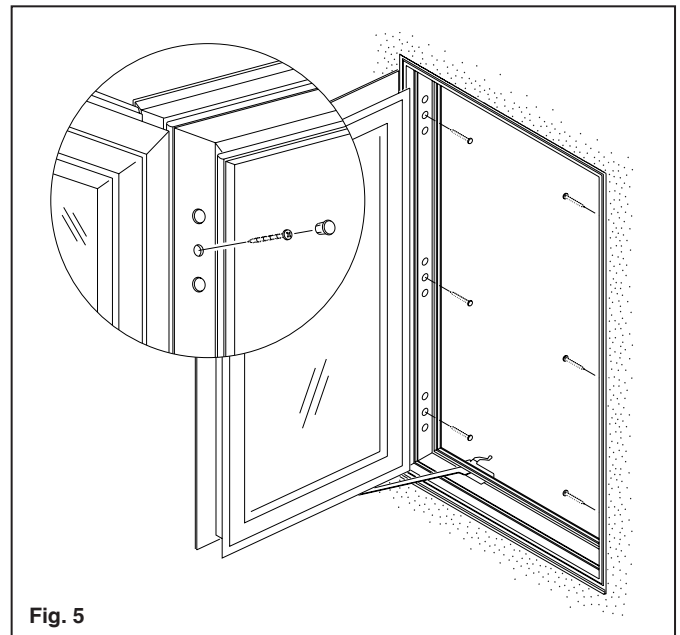

Fig. 5

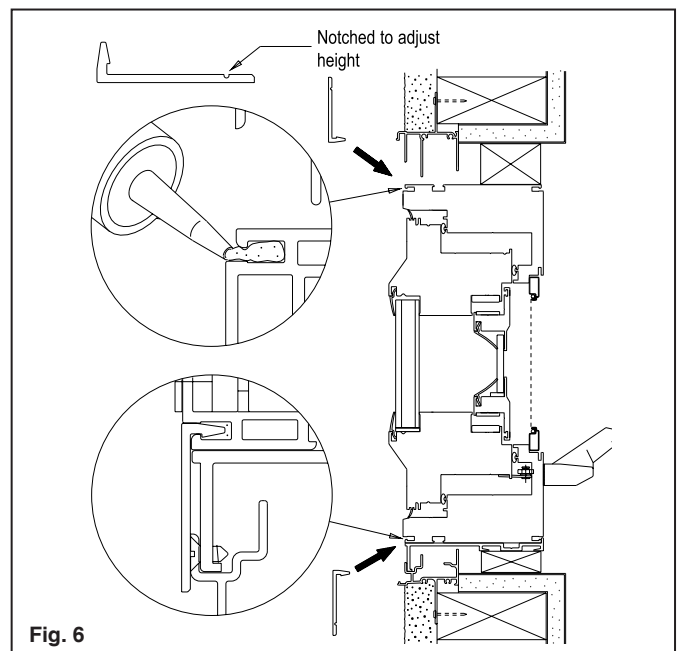

Fig. 6

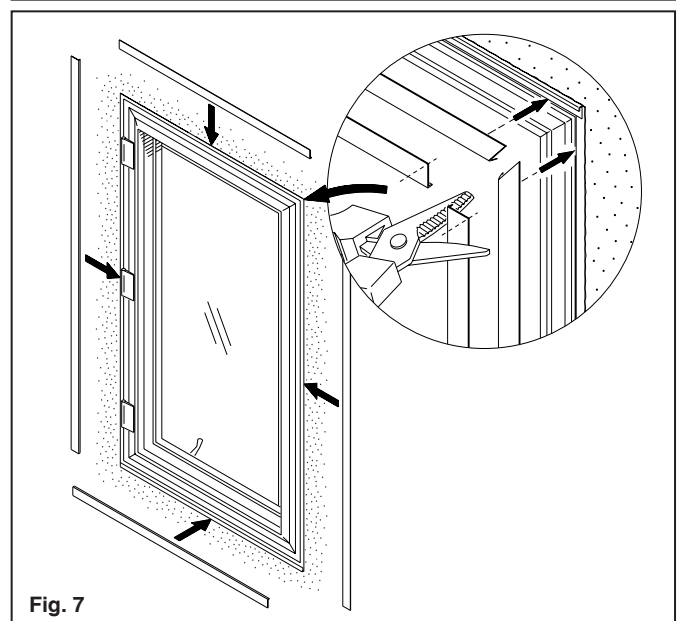

Fig. 7

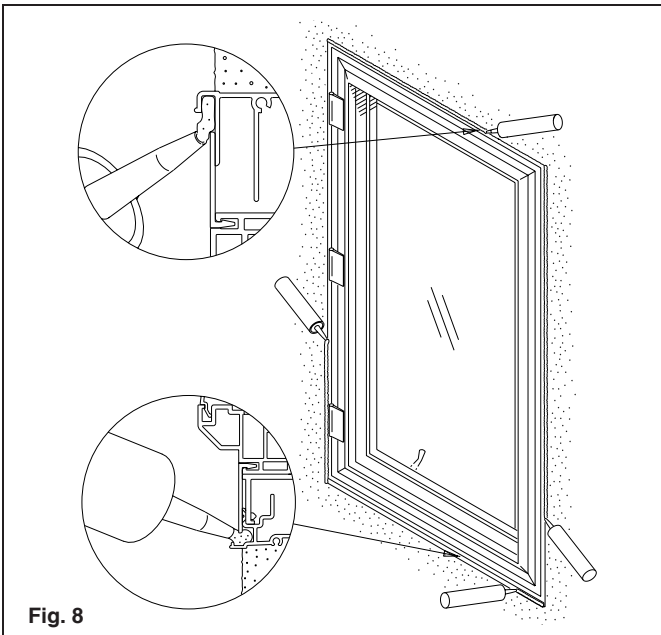

Fig. 8

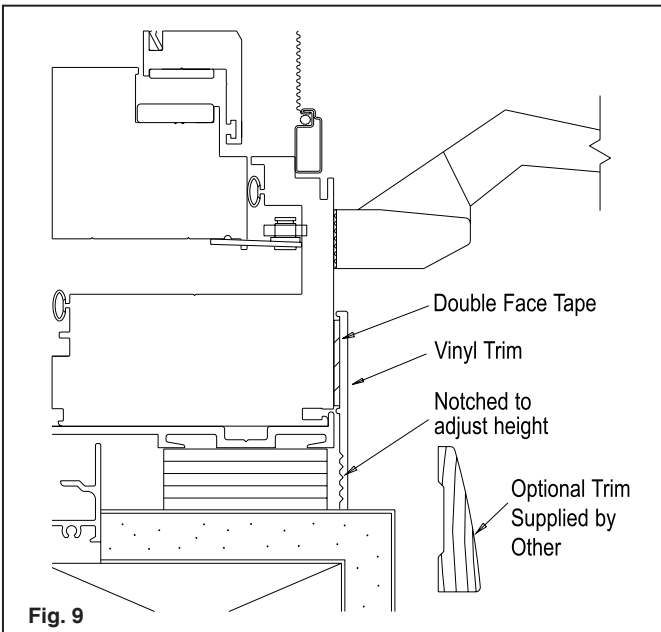

Fig. 9

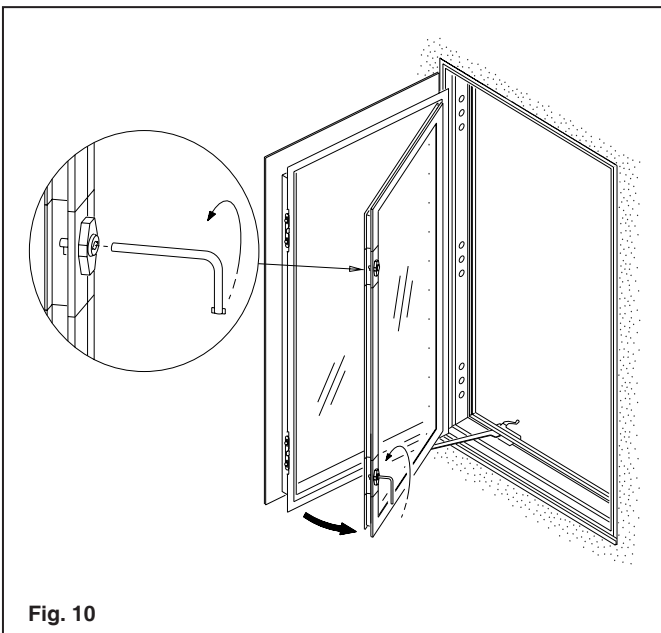

Fig. 10

- Wood trim, plant-ons, and pot shelves all require special precautions. When necessary under these conditions use metal flashing. Use metal flashing on any surfaces where water may not drain promptly.
- Seal all holes in the building paper including those caused by staples or nails.
- Interfaces between our products, flashing and the building's weather resistive barrier must be sealed with a sealant recommended for this application. We cannot recommend a particular type or manufacturer of sealant.
- Muller windows require special treatment. Please consult instructions for your muller conditions.
- Holes drilled for alarms may not be placed on sills or heads and must be sealed.
- Extreme weather conditions may cause water intrusion into your home and subsequent water damage. Consult a licensed engineer for an appropriate rating for expected local weather conditions.
- Do not apply film or tints to the surface of the glass. These products can cause insulated unit failure.
- To avoid the effects of electrolysis and chemical reaction to an aluminum sill, apply bituminous paint to raw masonry or concrete. You may also use a PVC liner to separate the metal frame from the substrate.

SEMI-ANNUAL MAINTENANCE

- Improperly maintained products will reduced the performance of any window or door. The sills and weeps must be cleaned regularly to allow for drainage. Water in the sill during a rainstorm is normal.
- Weather-strip should be cleaned and fluffed on a regular basis. Wearing of the wool pile is normal. Wool pile should be replaced if gaps between the weather-strip and frame appear.
- Harsh abrasive cleaners should never be used on frames or glass surface.
- If products are within 10 miles of the coast, metal surfaces should be cleaned with a fresh water rinse every one to three months. Car wax on the surface will provide some protection. Anodized or painted surfaces will help prolong the life and enhance appearance. Clean and lubricate hardware components with corrosion resistant spray or lubricant monthly to ensure proper performance. Silicone lubricant spray can be used on all operable components.

REMOVAL OF OLD WINDOWS OR DOORS

Some things to keep in mind when removing old products.

- Follow the EPA's Lead Renovation, Repair and Painting Rule (RRP Rule) which requires that firms performing renovation, repair, and painting projects that disturb lead-based paint in homes, child care facilities and pre-schools built before 1978 have their firm certified by EPA (or an EPA authorized state), use certified renovators who are trained by EPA-approved train providers and follow lead-safe work practices. For more information visit www.epa.gov/lead.
- When removing products from a building IWC recommends that you follow local rules and regulations for disposal. Whenever possible, take window and door products or components to reuse or recycling centers and avoid disposing them in the landfill. Consult with your local recycling center for more information on programs in your area.

Installation Instructions: IWC provides installation instructions for common new construction and replacement applications found at www.intlwindow.com. Some IWC products have specific installation instructions which are also available on the website. For variations of these installation instructions or questions regarding alternative installation practices, call 1.800.477.4032 for more information.

Disclaimer: EPA makes no warranties, expressed or implied, nor assumes any legal liability or responsibility for the accuracy, completeness, or usefulness of the contents of installation instructions, or any portion thereof. Further, EPA cannot be held liable for defects or deficiencies resulting from the proper or improper application of installation instructions.

PLEASE KEEP THESE INSTRUCTIONS IN YOUR HOME OWNER'S PACKET.

I have read the above instructions and understand the manufacturer's recommendations.

.....
(Installer's signature)



Southern California
1.800.477.4032

Visit our website at www.intlwindow.com